

Installation guide/Connection Diagram XBB Kit 270425 / 270435

Installera alltid XBB Dongle® först så du vet att det finns ett lämpligt recept till din bil!

- Kontrollera att din bil finns med i [receptlistan](#) på www.strands.se
 - Finns inte exakt din modell med i listan så är enda sättet att ta reda på om det fungerar genom att **DU** kopplar in en XBB Dongle® och provar olika recept från snarlika bilmodeller.
 - Ladda ner appen XBB Configurator från [Google Play](#) eller [App Store](#).
 - Starta appen och registrera ett konto.
 - Verifiera kontot med koden som skickas till din epost. (Kommer inget mail så kolla i Skräpposten)
 - Du måste ha Platsinställningar aktiverat i telefonen för att du ska hitta på XBB Dongle® & XBB PowerUnit®
-

Installation av XBB Dongle®

- Lokalisera din bils diagnosuttag (OBD2). Den bör sitta in närheten av ratten, oftast vid förarens benutrymme. Det kan även sitta en liten lucka som döljer uttaget.
- Montera din XBB Dongle® i OBD2 uttaget, säkerställ att den är ordentligt intryckt i uttaget.
- Starta appen och klicka på "Skanna efter XBB Dongle".
- Klicka på den XBB Dongle® som dyker upp för att fortsätta installationen.
- Följ anvisningen om Firmwareuppdatering om en sådan är rekommenderad.
- Klicka återigen på "Skanna efter XBB Dongle" och välj den när den dyker upp i appen. Skulle den inte synas så ta ut den ut bilens OBD2 uttag och sätt tillbaka den igen.
OBS! XBB Dongle® är bara synlig i 10 minuter efter att man stängt ner appen, vill man att den alltid ska vara synlig måste man para ihop den med telefonen via huvudmenyn i appen.
- Välj Recept baserat på vad du har för bil. **OBS!** Ligger det redan ett recept i XBB Dongle ex. Q.C Test recipe måste det först tas bort innan man väljer ett nytt. Klicka på settings och välj Ta bort XBB Dongle-receptet.
- Kontrollera att de signaler/funktioner du är intresserad av fungerar i appen genom att prova dem i bilen. Exempel, om du aktiverar helljuset på bilen så ska HIGHBEAM ändra status till PÅ och bli grönmarkerad. Samma gäller för övriga signaler. Vill du prova ett annat recept klickar du på settings och väljer ta bort XBB Dongle-recept, välj sedan ett nytt recept och testa funktionerna på nytt.
- **OBS Viktigt!** Avsluta installationen av XBB Dongle med att stänga av och lås/larma bilen. Kontrollera sedan i appen om signalen SYSTEM_ACTIVE finns med. Finns den signalen med är det viktigt att den blir rödmarkerad efter ca 2 minuter efter det att du låst/larmat bilen. **OBS!** Sitt inte kvar i bilen när du gör denna test. Skulle den **INTE** bli rödmarkerad så stämmer inte receptet riktigt med din bil och det finns risk att bilens batteri blir urladdat. Prova i så fall ett annat recept.

Always install the XBB Dongle® first so you know there is a suitable recipe for your car!

- Check that your car is included in the [recipe list](#) on www.strandseurope.com
 - If your model is not exactly in the list, the only way to find out if it will work correctly is for **YOU** to plug in an XBB Dongle® and try different recipes from similar car models.
 - Download the XBB Configurator app from [Google Play](#) or [the App Store](#).
 - Launch the app and register an account.
 - Verify your account with the code sent to your email. (If you don't get an email, check your spam folder)
 - You must have Location Settings enabled on your phone to find your way around the XBB Dongle® & XBB PowerUnit®
-

Installation of the XBB Dongle®

- Locate your car's diagnostic socket (OBD2). It should be located close to the steering wheel, usually at the driver's legroom. There may also be a small hatch that hides the socket.
- Mount your XBB Dongle® in the OBD2 socket, making sure it is firmly inserted into the socket.
- Launch the app and click on "Scan for XBB Dongle".
- Click on the XBB Dongle® that pops up to continue the installation.
- Follow the Firmware Update instructions if one is recommended.
- Again, click on "Scan for XBB Dongle" and select it when it shows up in the app. Should it not be visible, take it out of the car's OBD2 socket and put it back in again.
NB! The XBB Dongle® is only visible for 10 minutes after you close the app, if you want it to always be visible you must pair it with the phone via the main menu in the app.
- Choose Recipes based on what kind of car you have. NB! If there is already a recipe in XBB Dongle, e.g. Q.C Test recipe, it must first be removed before choosing a new one. Click on settings and select Delete XBB Dongle Recipe.
- Check that the signals/functions you are interested in work in the app by trying them out in the car. For example, if you activate the high beam headlights on the car, HIGHBEAM should change the status to ON and be highlighted green. The same applies to other signals. To try a different recipe, click settings and select Remove XBB Dongle Recipe, then select a new recipe and test the features again.
- **NOTE!** Always finish the installation of the XBB Dongle by switching off and locking/alarming the car. Then check the app to see if the signal SYSTEM_ACTIVE is present. If that signal is present, it is important that it is marked in red after about 2 minutes after you have locked/alarmed the car. NB! Do not remain in the car while taking this test. Should it **NOT** be marked in red, the recipe does not match your car and there is a risk that the car's battery will be discharged. If so, try a different recipe.

Cable length
meter

Area

Load
Ampere Watt

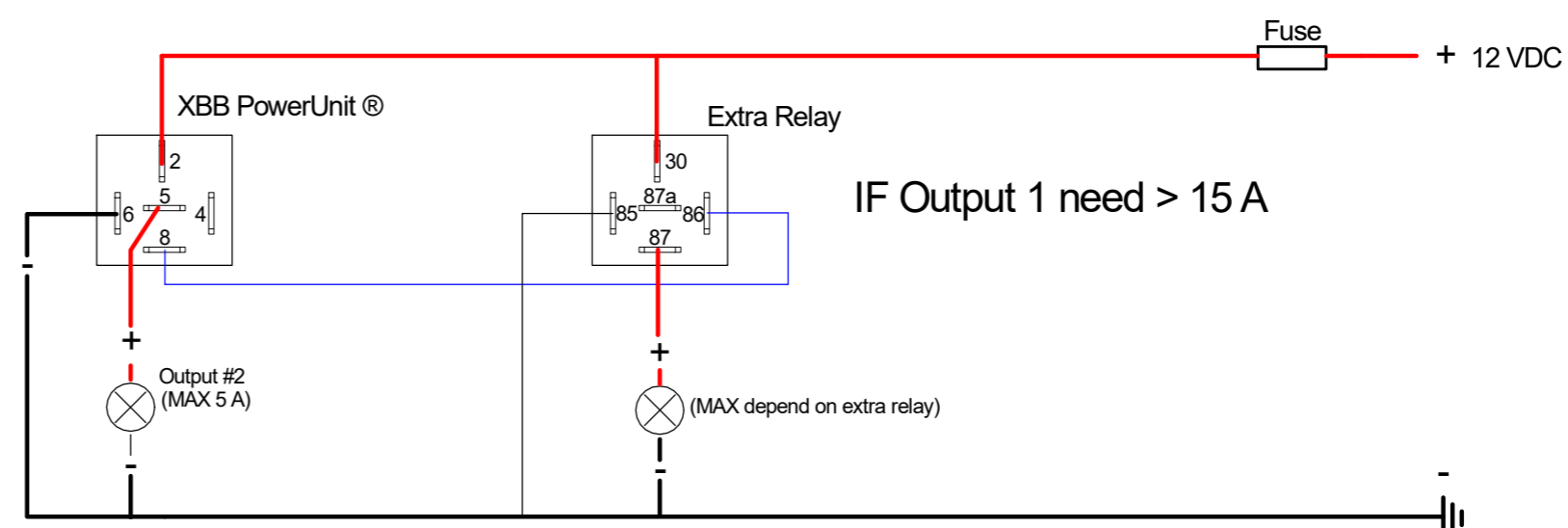
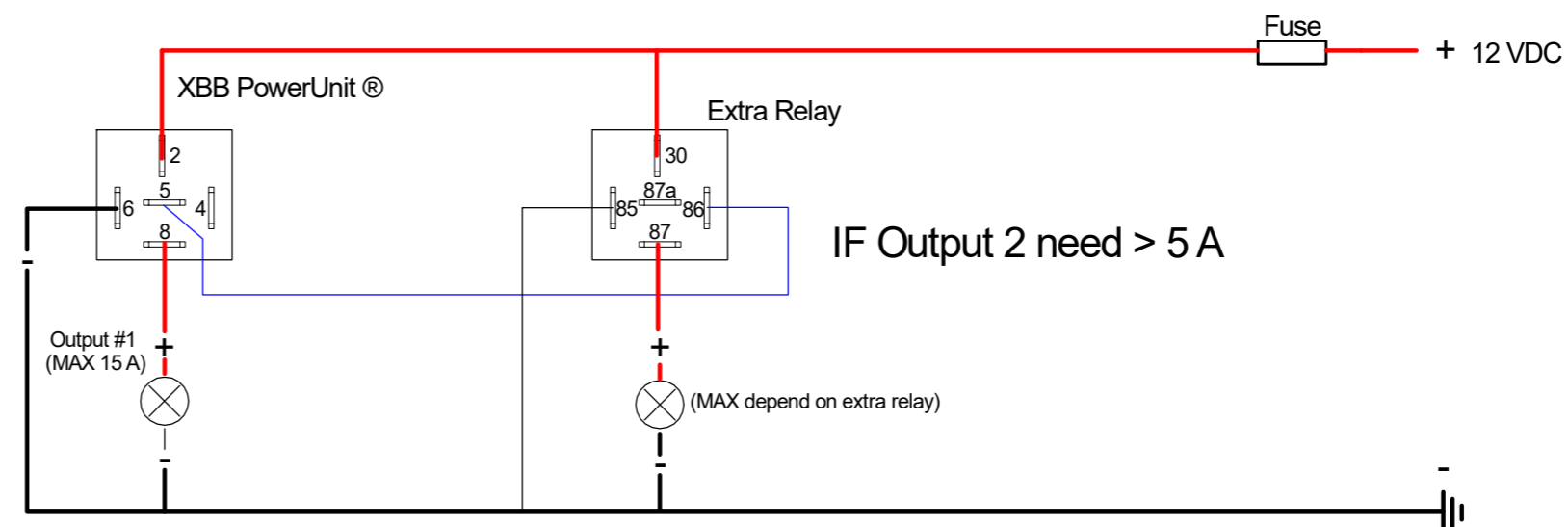
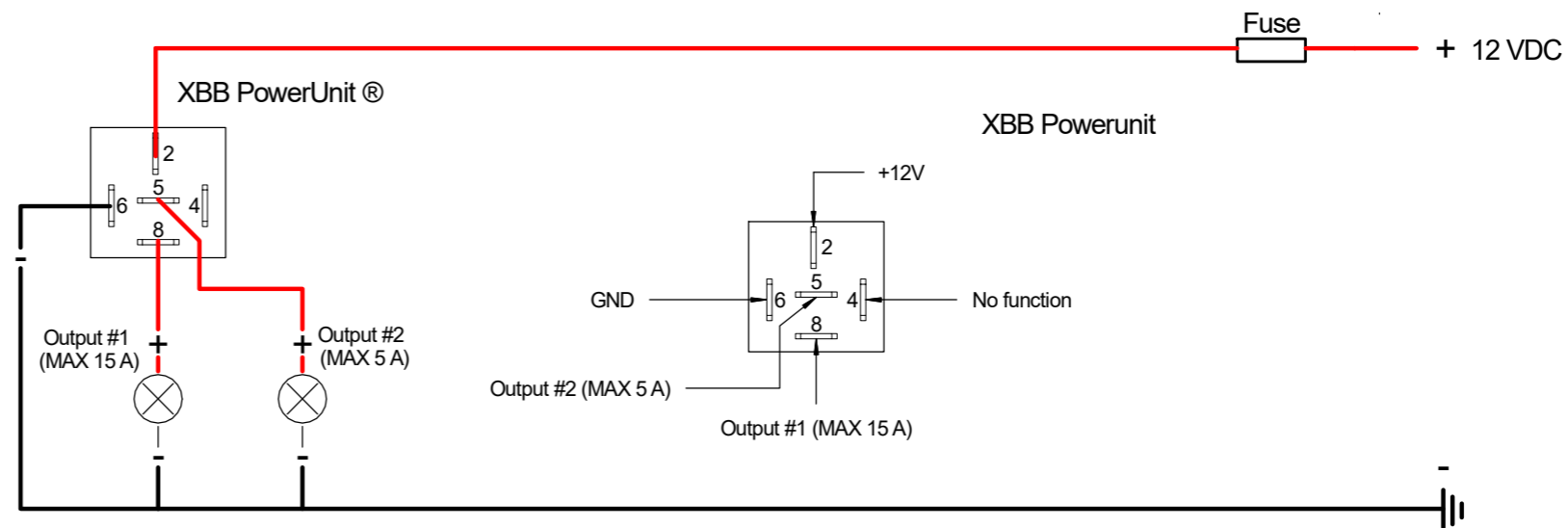
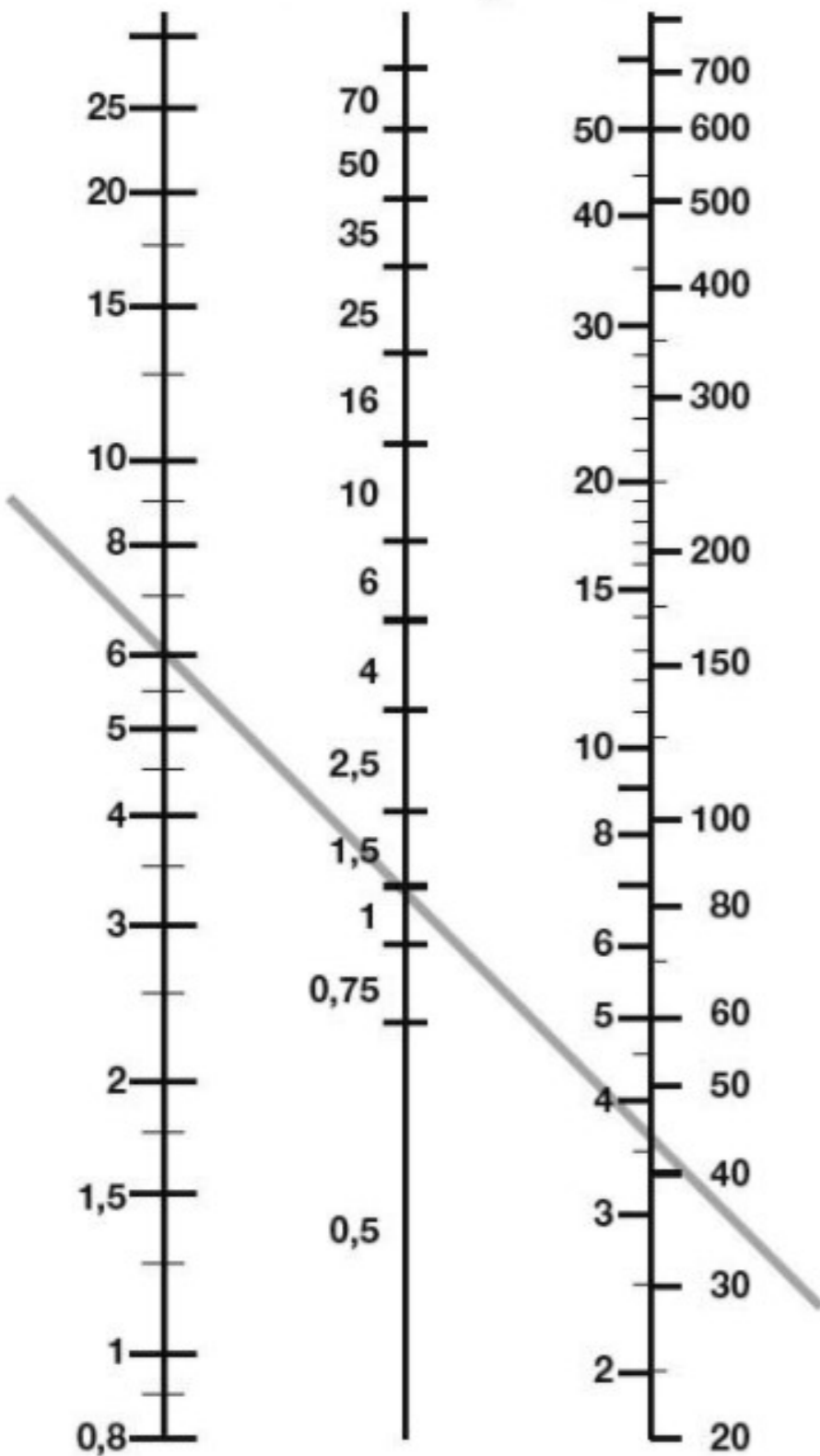

STRANDS GROUP AB

Mounting direction:

A very important step is the placement and mounting direction of the XBB PowerUnit™. When installing XBB PowerUnit™ in the engine compartment it is very important to mount the XBB PowerUnit™ with the socket pointing downwards. XBB PowerUnit™ has IP 53 protection only when mounted with the socket downwards.

Note!

Avoid using water to wash the surrounding parts and XBB PowerUnit™. If you must use water or pressure washer, please remove XBB PowerUnit™ from the relay socket before using water.

Placement from the XBB Dongle™ should be as short as possible. Even though both XBB PowerUnit™ and XBB Dongle™ have a relatively high output power, the signal can be disturbed due to encapsulation depending on vehicle construction and/or damping materials.

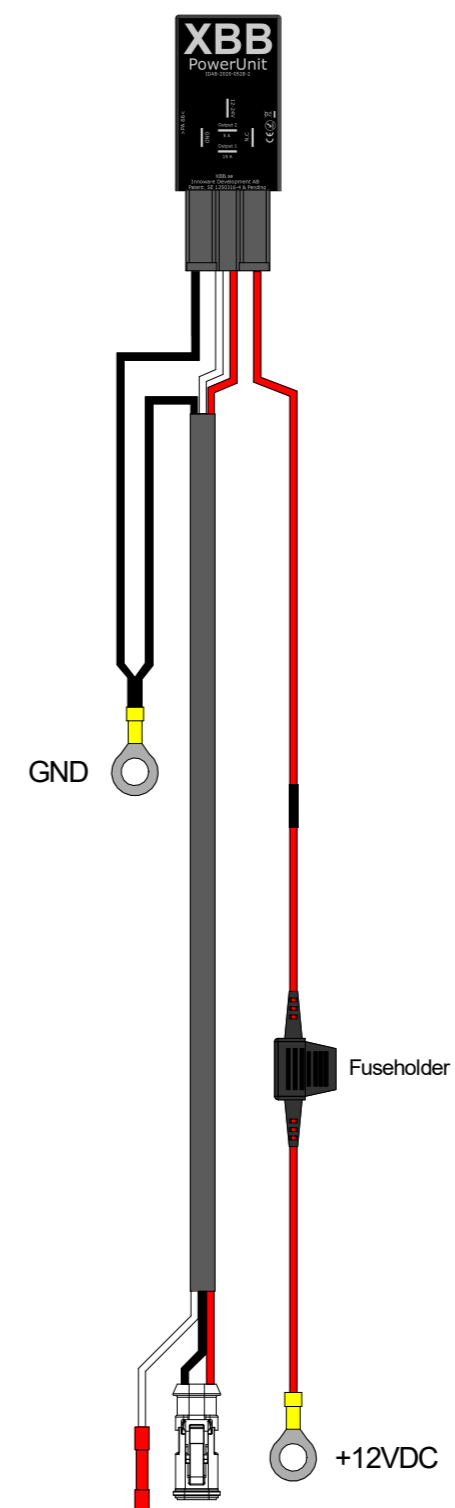
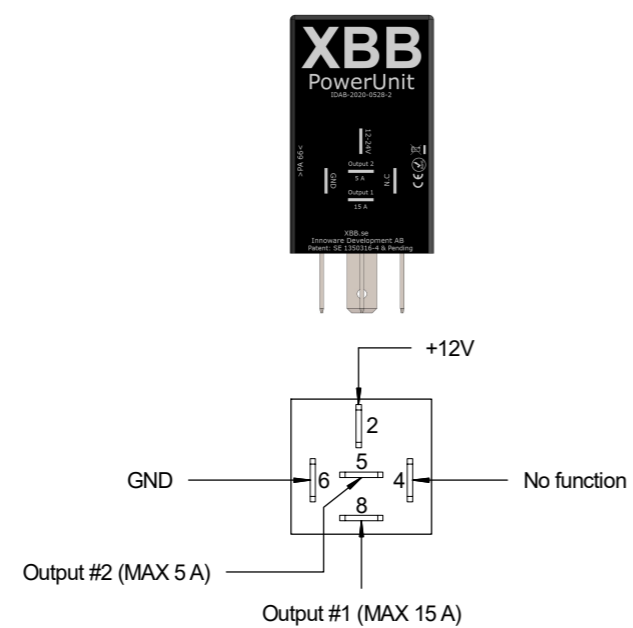

Mounting direction:

A very important step is the placement and mounting direction of the XBB PowerUnit™. When installing XBB PowerUnit™ in the engine compartment it is very important to mount the XBB PowerUnit™ with the socket pointing downwards. XBB PowerUnit™ has IP 53 protection only when mounted with the socket downwards.

Note!

Avoid using water to wash the surrounding parts and XBB PowerUnit™. If you must use water or pressure washer, please remove XBB PowerUnit™ from the relay socket before using water.

Placement from the XBB Dongle™ should be as short as possible. Even though both XBB PowerUnit™ and XBB Dongle™ have a relatively high output power, the signal can be disturbed due to encapsulation depending on vehicle construction and/or damping materials.

